

REF. 5.043

SF809E Sillón tapizado

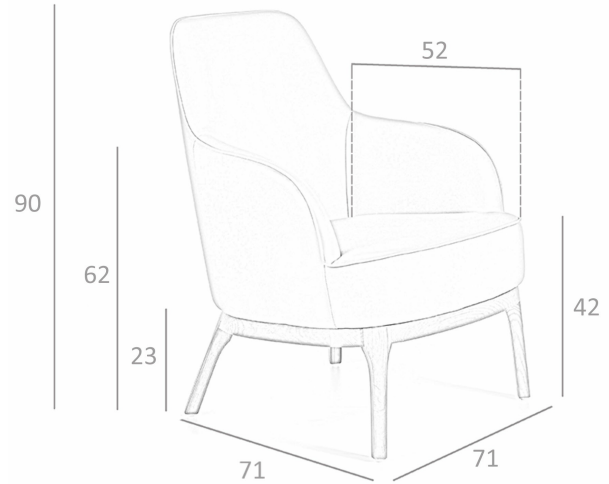

MEDIDAS

Medidas: 71 x 71 x 90 cm.

Peso: 16 Kg.

Metraje: 3 (x1,4) m.

EMBALAJE

81 x 73 x 69 cm. / 18 Kg.

VOLUMEN

0,52 m³

PRODUCTO

Polipiel - Stock - Similar Acua 18

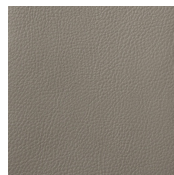

PATAS

Material Patas: Madera color Nogal

