

**REF. 4.094**

**WD1582B Silla**

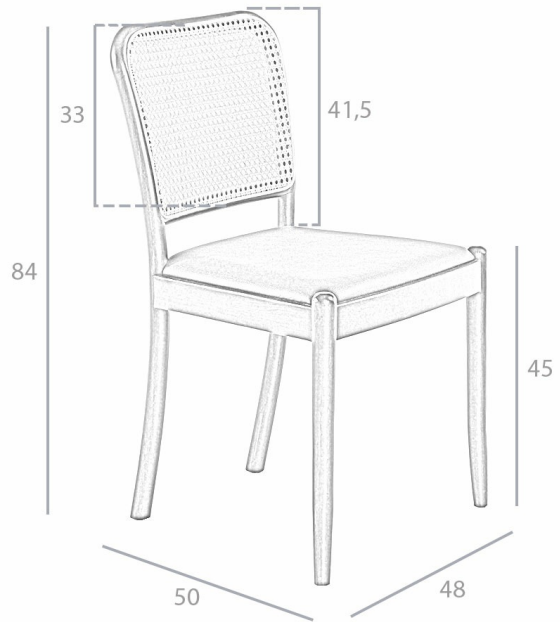

**MEDIDAS**

Medidas: 48 x 50 x 84 cm.

Peso: 6,5 Kg.

**EMBALAJE**

70 x 50 x 101 cm. / 15 Kg.

**VOLUMEN**

0,18 m3

**PRODUCTO**

Polipiel - Stock - Similar Acua 90

Rattan

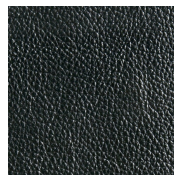

**PATAS**

Material Patas: Madera color Nogal

