

**REF. 4.063**

**CH1512-NOGAL Silla**

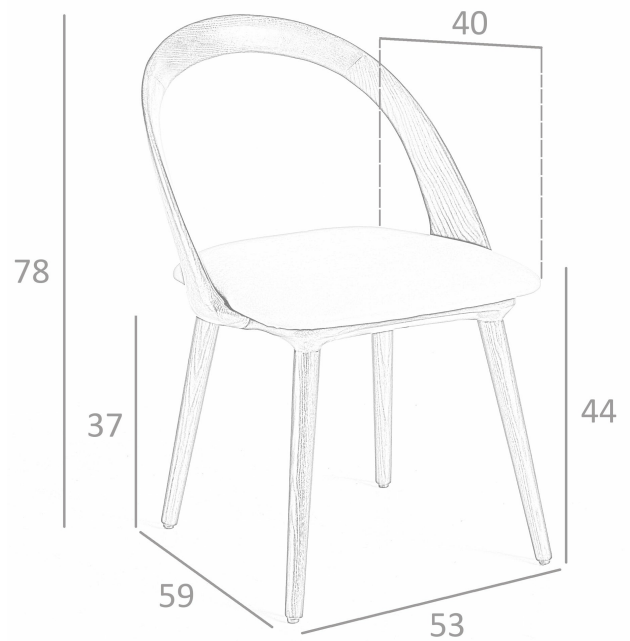

**MEDIDAS**

Medidas: 53 x 59 x 78 cm.

Peso: 9 Kg.

Metraje: 0,75 (x1,4) m.

**EMBALAJE**

95 x 95 x 55 cm. / 19 Kg.

**VOLUMEN**

0,29 m3

**PRODUCTO**

Polipiel - Stock - Similar Acua 18

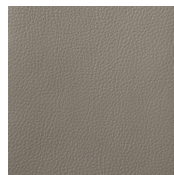

**PATAS**

Material Patas: Madera Fresno color Nogal

